

Protector™ Series

Diesel Generator Set

INCLUDES:

- Two Line LCD Multilingual Digital Evolution™ Controller (English/Spanish/French/Portuguese) with external viewing window for easy indication of generator status and breaker position.
- Isochronous Electronic Governor
- Sound Attenuated Aluminum Enclosure
- Smart Battery Charger
- UV/Ozone Resistant Hoses
- ±1% Voltage Regulation
- Integrated Base Tank Provides Up to 50 Hours of Run Time
- 3 Year Limited Warranty

Not for sale in US/CA

Standby Power Rating

Model RD015 - 15 kW 60 Hz

Model RD020 - 20 kW 60 Hz

Model RD030 - 30 kW 60 Hz

Model RD048 - 48 kW 60 Hz (single phase only)

Model RD050 - 50 kW 60 Hz (three phase only)



QUIET-TEST™



*Built in the USA using domestic and foreign parts

FEATURES

- **INNOVATIVE DESIGN & PROTOTYPE TESTING** are key components of GENERAC'S success in "IMPROVING POWER BY DESIGN." But it doesn't stop there. Total commitment to component testing, reliability testing, environmental testing, destruction and life testing, plus testing to applicable CSA, NEMA, EGSA, and other standards, allows you to choose GENERAC POWER SYSTEMS with the confidence that these systems will provide superior performance.
- **TEST CRITERIA:**
 - ✓ PROTOTYPE TESTED
 - ✓ SYSTEM TORSIONAL TESTED
 - ✓ NEMA MG1-22 EVALUATION
 - ✓ MOTOR STARTING ABILITY
- **SOLID-STATE, FREQUENCY COMPENSATED VOLTAGE REGULATION.** This state-of-the-art power maximizing regulation system is standard on all Generac models. It provides optimized FAST RESPONSE to changing load conditions and MAXIMUM MOTOR STARTING CAPABILITY by electronically torque-matching the surge loads to the engine. Digital voltage regulation at ±1%.
- **SINGLE SOURCE SERVICE RESPONSE** from Generac's extensive dealer network provides parts and service know-how for the entire unit, from the engine to the smallest electronic component.
- **GENERAC TRANSFER SWITCHES.** Long life and reliability are synonymous with GENERAC POWER SYSTEMS. One reason for this confidence is that the GENERAC product line includes its own transfer systems and controls for total system compatibility.

15 • 20 • 30 • 48 • 50 kW**application & engineering data****GENERATOR SPECIFICATIONS**

Type	Synchronous
Rotor Insulation Class	H (15 & 20 kW) or F (30, 48 & 50 kW)
Stator Insulation Class	H
Telephone Interference Factor (TIF)	<50
Alternator Output Leads 1-Phase	3 wire
Alternator Output Leads 3-Phase	6 wire
Bearings	Single Sealed Cartridge
Coupling	Direct, Flexible Disc
Excitation System	Direct

VOLTAGE REGULATION

Type	Electronic
Sensing	Single Phase
Regulation	± 1%
Features	Adjustable Voltage & Gain

GOVERNOR SPECIFICATIONS

Type	Electronic Isochronous
Steady State Regulation	± 0.25%

ELECTRICAL SYSTEM

Battery Charge Alternator	50 Amp (15 & 20 kW) or 70 Amp (30, 48 & 50 kW)
Static Battery Charger	2 Amp
Recommended Battery (battery not included)	Group 27F, 700 CCA
System Voltage	12 Volts

GENERATOR FEATURES

<p>Revolving field heavy duty generator Directly connected to the engine Operating temperature rise 120°C above a 40°C ambient Class H insulation is NEMA rated Class F insulation is NEMA rated All models fully prototype tested</p>

ENCLOSURE FEATURES

Aluminum weather protective enclosure	Ensures protection against mother nature. Electrostatically applied textured epoxy paint for added durability.
Enclosed critical grade muffler	Quiet, critical grade muffler is mounted inside the unit to prevent injuries and maximize sound dampening.
Small, compact, attractive	Makes for an easy, eye appealing installation.
SAE	Sound attenuated enclosure ensures quiet operation.

15 • 20 • 30 • 48 • 50 kW

application & engineering data

ENGINE SPECIFICATIONS: 15 & 20 kW

Make	Generac
Model	In-line
Cylinders	4
Displacement (Liters)	2.28
Bore (in/mm)	3.46/88
Stroke (in/mm)	3.70/94
Compression Ratio	21.3:1
Intake Air System	Naturally Aspirated
Cylinder Head Type	Cast Iron OHV
Piston Type	Aluminum

ENGINE SPECIFICATIONS: 30 kW

Make	Generac
Model	In-line
Cylinders	4
Displacement (Liters)	2.4
Bore (in/mm)	3.54/90
Stroke (in/mm)	3.70/94
Compression Ratio	21.3:1
Intake Air System	Turbocharged
Cylinder Head Type	Cast Iron OHV
Piston Type	Aluminum

ENGINE SPECIFICATIONS: 48/50 kW

Make	Generac
Model	In-Line
Cylinders	4
Displacement (Liters)	3.4
Bore in/mm	3.86/98
Stroke in/mm	4.45/113
Compression Ratio	18.5:1
Intake Air System	Turbocharged/Aftercooled
Cylinder Head Type	Cast Iron OHV
Piston Type	Aluminum

ENGINE LUBRICATION SYSTEM

Oil Pump Type	Gear
Oil Filter Type	Full flow spin-on canister
Crankcase Capacity (quarts/liters)	6.87/6.5 - 15 & 20 kW
	6.8/6.4 - 30 kW
	7.4/7 - 48 & 50 kW

ENGINE COOLING SYSTEM

Type	Pressurized radiator -15 & 20 kW Closed recovery - 30, 48 & 50 kW
Water Pump	Pre-lubed, self-seating
Fan Speed (rpm)	1800 - 15 & 20 kW
	2061 - 30 kW
	2029 - 48 & 50 kW
Fan Diameter (in/mm)	18.11/460 (15 & 20 kW) 22/559 (30, 48 & 50 kW)
Fan Mode	Pusher

FUEL SYSTEM

Fuel Type	Ultra Low Sulfur Diesel Fuel
Fuel Pump Type	Mechanical Engine Driven Gear
Injector Type	Mechanical
Fuel Supply Line (mm/in)	7.94/0.31 (ID)
Fuel Return Line (mm/in)	7.94/0.31(ID)
Fuel Specification	ASTM
Fuel Filtering (microns)	5 - 15, 20 & 30 kW
	10 - 48 & 50 kW

TANK SPECIFICATIONS

Total Size (gallons/liters)	45/170.3 - 15 & 20 kW
	68/257.4 - 30, 48 & 50 kW
Usable Size (gallons/liters)	40/151.4 - 15 & 20 kW
	61/230.9 - 30, 48 & 50 kW
Run Time @ 1/2 Load (hrs)	50.6 - 15 kW
	38.1 - 20 kW
	40.7 - 30 kW
	26.5 - 48 & 50 kW

WEIGHTS AND DIMENSIONS

	15 kW	20 kW	30 kW	48 kW	50 kW
Weight (lb/kg)	1224/555		1689/766	1953/886	
Dimensions (LxWxH) (in/cm)	62 x 31 x 49/158 x 78 x 124		77 x 35 x 55/195 x 89 x 141		

15 • 20 • 30 • 48 • 50 kW

operating data

GENERATOR OUTPUT VOLTAGE/kW - 60 Hz

		kW (Standby)	Amp (Standby)	kW (Prime)	Amp (Prime)	CB Size
RD015	120/240 V, 1Ø, 1.0 pf	15	62	12	50	70
	120/208 V, 3Ø, 0.8 pf	15	52	12	42	60
	120/240 V, 3Ø, 0.8 pf	15	45	12	36	50
RD020	120/240 V, 1Ø, 1.0 pf	20	83	16	67	100
	120/208 V, 3Ø, 0.8 pf	20	69	16	56	80
	120/240 V, 3Ø, 0.8 pf	20	60	16	48	70
RD030	120/240 V, 1Ø, 1.0 pf	30	125	24	100	150
	120/208 V, 3Ø, 0.8 pf	30	104	24	83	125
	120/240 V, 3Ø, 0.8 pf	30	90	24	72	100
	277/480 V, 3Ø, 0.8 pf	30	45	24	36	50
RD048 & RD050	120/240 V, 1Ø, 1.0 pf	48	200	38.4	183	200
	120/208 V, 3Ø, 0.8 pf	50	173	40	153	200
	120/240 V, 3Ø, 0.8 pf	50	150	40	132	175
	277/480 V, 3Ø, 0.8 pf	50	75	40	66	90

SURGE CAPACITY IN AMPS

		Voltage Dip @ < .4 pf	
		15%	30%
RD015	120/240 V, 1Ø	53	129
	120/208 V, 3Ø	37	90
	120/240 V, 3Ø	32	78
RD020	120/240 V, 1Ø	87	211
	120/208 V, 3Ø	59	143
	120/240 V, 3Ø	51	124
RD030	120/240 V, 1Ø	66	168
	120/208 V, 3Ø	59	144
	120/240 V, 3Ø	51	125
	277/480 V, 3Ø	26	64
RD048 & RD050	120/240 V, 1Ø	69	189
	120/208 V, 3Ø	90	218
	120/240 V, 3Ø	78	189
	277/480 V, 3Ø	36	87

ENGINE FUEL CONSUMPTION

		gal/hr	L/hr
RD015	25% of rated load	0.51	1.93
	50% of rated load	0.79	2.99
	75% of rated load	1.14	4.31
	100% of rated load	1.48	5.58
RD020	25% of rated load	0.67	2.6
	50% of rated load	1.05	3.97
	75% of rated load	1.52	5.32
	100% of rated load	1.98	7.48
RD030	25% of rated load	0.92	3.5
	50% of rated load	1.45	5.5
	75% of rated load	1.96	7.4
	100% of rated load	2.74	10.4
RD048 & RD050	25% of rated load	1.35	5.11
	50% of rated load	2.15	8.14
	75% of rated load	3.06	11.58
	100% of rated load	3.98	15.07

STANDBY RATING: Standby ratings apply to installations served by a reliable utility source. The standby rating is applicable to varying loads for the duration of a power outage. There is no overload capability for this rating. Ratings are in accordance with ISO-3046-1. Design and specifications are subject to change without notice.

15 • 20 • 30 • 48 • 50 kW

operating data

ENGINE COOLING

	15 kW	20 kW	30 kW	48 & 50 kW
Air flow (inlet air including alternator and combustion air in cfm/cmm)	2824/80	2824/80	3038/86	2824/80
System coolant capacity (gal/liters)	2.8/10.6	2.8/10.6	2.8/10.6	2.8/10.6
Heat rejection to coolant (BTU per hr/MJ per hr)	63,535/67	63,535/67	111,000/117.1	135,900/143.4
Maximum operation air temperature on radiator (°C/°F)	50/122			
Maximum ambient temperature (°C/°F)	50/122			

COMBUSTION REQUIREMENTS

Flow at rated power (cfm/cmm)	84.76/2.4	84.76/2.4	90/2.55	190/5.38
-------------------------------	-----------	-----------	---------	----------

SOUND EMISSIONS

Sound output in dB(A) at 23 ft (7 m) with generator in exercise mode*	65
Sound output in dB(A) at 23 ft (7 m) with generator operating at normal load*	70

*Sound levels are taken from the front of the generator. Sound levels taken from other sides of the generator may be higher depending on installation parameters.

EXHAUST

Exhaust flow at rated output (cfm/cmm)	98.88/2.8	98.88/2.8	230/6.51	448/12.7
Exhaust temperature at rated output (°C/°F)	510/950	510/950	454.4/850	604.4/1120

ENGINE PARAMETERS

Rated Synchronous RPM	1800			
HP at rated kW	26.4	33.5	49	85

POWER ADJUSTMENT FOR AMBIENT CONDITIONS

Temperature Deration	3% for every 5 °C above 25 °C or 1.7% for every 5 °F above 77 °F
Altitude Deration (15, 30, 48 & 50 kW)	1% for every 100 m above 915 m or 3% for every 1000 ft above 3000 ft
Altitude Deration (20 kW)	1% for every 100 m above 305 m or 3% for every 1000 ft above 1000 ft

CONTROLLER FEATURES

2-Line Plain Text Multilingual LCD Display	Simple user interface for ease of operation.
Mode Buttons: Auto	Automatic Start on Utility failure. Programmable 7 day exerciser.
Manual	Start with starter control, unit stays on. If utility fails, transfer to load takes place.
Off	Stops unit. Power is removed. Control and charger still operate.
Ready to Run/Maintenance Messages	Standard
Engine Run Hours Indication	Standard
Programmable start delay between 2-1500 seconds	Standard (programmable by dealer only)
Utility Voltage Loss/Return to Utility Adjustable	From 140-171 V/190-216 V
Future Set Capable Exerciser/Exercise Set Error Warning	Standard
Run/Alarm/Maintenance Logs	50 Events Each
Engine Start Sequence	Cyclic cranking: 16 sec on, 7 rest (90 sec maximum duration).
Starter Lock-out	Starter cannot re-engage until 5 sec after engine has stopped.
Smart Battery Charger	Standard
Charger Fault/Missing AC Warning	Standard
Low Battery/Battery Problem Protection and Battery Condition Indication	Standard
Automatic Voltage Regulation with Over and Under Voltage Protection	Standard
Under-Frequency/Overload/Stepper Overcurrent Protection	Standard
Safety Fused/Fuse Problem Protection	Standard
Automatic Low Oil Pressure/High Oil Temperature Shutdown	Standard
Overcrank/Overspeed (@ 72 Hz)/RPM Sense Loss Shutdown	Standard
High Engine Temperature Shutdown	Standard
Internal Fault/Incorrect Wiring Protection	Standard
Common External Fault Capability	Standard
Field Upgradable Firmware	Standard

15 & 20 kW

Drawing #0K7394-A (1 of 2)

SERVICE ITEM	2.3L	WEIGHT DATA WITH EMPTY BASE TANK (SEE NOTE 5)
OIL FILL CAP	RIGHT SIDE	GENERATOR AS SHOWN 555 (1224)
OIL DIP STICK	RIGHT SIDE	WITH WOODEN SHIPPING SKID 594 (1370)
OIL FILTER	RIGHT SIDE	WEIGHT: KG (LBS)
OIL DRAIN HOSE	RIGHT SIDE	DIMENSIONS: MM (INCH)
RADIATOR DRAIN HOSE	LEFT SIDE	
COOLANT RECOVERY BOTTLE	LEFT SIDE	
RADIATOR FILL CAP ACCESS	ROOF TOP	
AIR CLEANER ELEMENT	EITHER SIDE	
MUFFLER	FRONT	
PAN BELT	EITHER SIDE	
BATTERY	LEFT SIDE	

REFERENCE OWNERS MANUAL FOR PERIODIC REPLACEMENT PART LISTINGS.

- NOTES:
- MINIMUM RECOMMENDED CONCRETE PAD SIZE: 1092 (437") WIDE X 4887 (74.5") LONG. REFERENCE INSTALLATION GUIDE SUPPLIED WITH UNIT FOR CONCRETE PAD GUIDELINES.
 - ALLOW SUFFICIENT ROOM ON ALL SIDES OF THE GENERATOR FOR MAINTENANCE AND SERVICING. THIS UNIT MUST BE INSTALLED IN ACCORDANCE WITH CURRENT APPLICABLE NFPA 37 AND NFPA 70 STANDARDS AS WELL AS ANY OTHER FEDERAL, STATE, AND LOCAL CODES.
 - SEE SPECIFIC MODEL OWNER'S MANUAL FOR BREAKER INFORMATION.
 - ACCESSIBLE THROUGH CUSTOMER ACCESS ASSEMBLY COVER PANEL TO ACCESS THE STUB-UP AREAS AS FOLLOWS:
 - HIGH VOLTAGE CONNECTION INCLUDING AC LOAD LEAD CONDUIT CONNECTION, NEUTRAL CONNECTION, AND BATTERY CHARGER 120VOLT AC (0.5 AMP MAX) CONNECTION.
 - BATTERY CHARGER 12VOLT DC (0.5 AMP MAX) CONNECTION.
 - AIR FILTER AND ACCESSORY RELAY CONNECTION (QTY 4).
 - CENTER OF GRAVITY AND WEIGHT MAY CHANGE DUE TO UNIT OPTIONS.
 - BOTTOM OF GENERATOR SET MUST BE ENCLOSED TO PREVENT PEST INTRUSION AND RECIRCULATION OF DISCHARGE AIR AND/OR IMPROPER COOLING AIR FLOW.
 - EXHAUST SYSTEM MAXIMUM BACK PRESSURE: 24 INCHES H2O.
 - EXHAUST SYSTEM MUST BE INSTALLED IN ACCORDANCE WITH ALL APPLICABLE LOCAL, STATE, AND FEDERAL CODES.
 - MOUNTING BOLTS OR STUDS TO MOUNTING SURFACE SHALL BE 5/8-11 GRADE 5 (USE STANDARD SAE TORQUE SPECS).
 - MUST ALLOW FREE FLOW OF INTAKE AIR, DISCHARGE AIR AND EXHAUST. SEE SPEC SHEET FOR MINIMUM AIR FLOW AND MAXIMUM RESTRICTION REQUIREMENTS.
 - GENERATOR MUST BE INSTALLED SUCH THAT FRESH COOLING AIR IS AVAILABLE AND THAT DISCHARGE AIR FROM RADIATOR IS NOT RECIRCULATED.

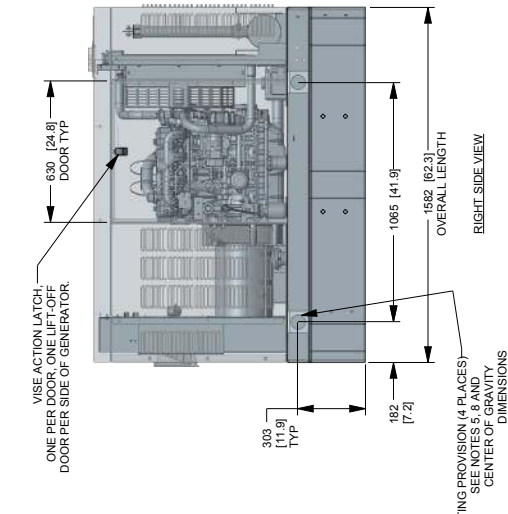
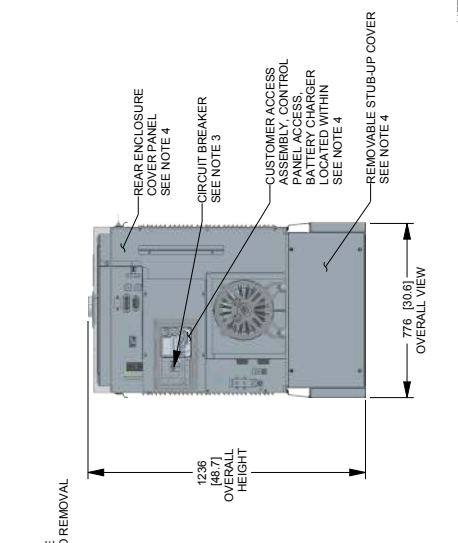
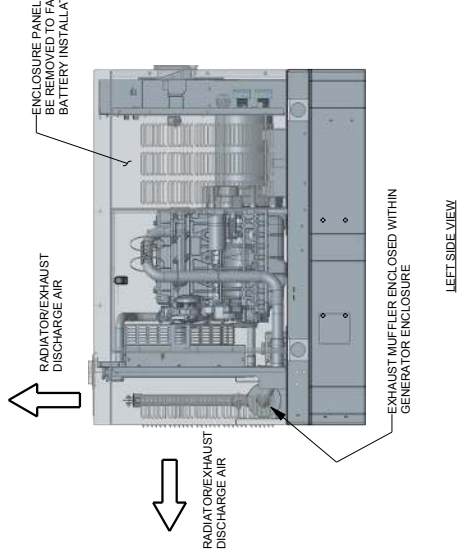
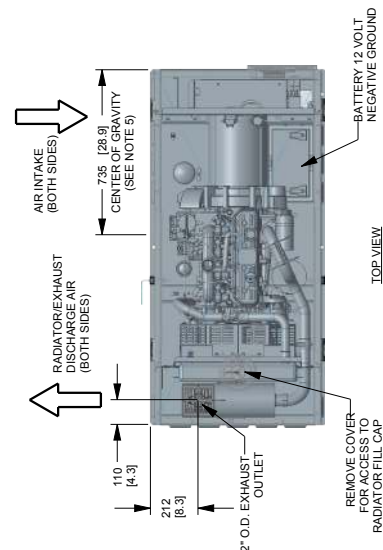

15 & 20 kW

FUEL TANK	
TOTAL CAPACITY	169 [44]
USABLE CAPACITY	151 [40]

CAPACITY, LITER (GALLON)
DIMENSIONS: MM (INCH)

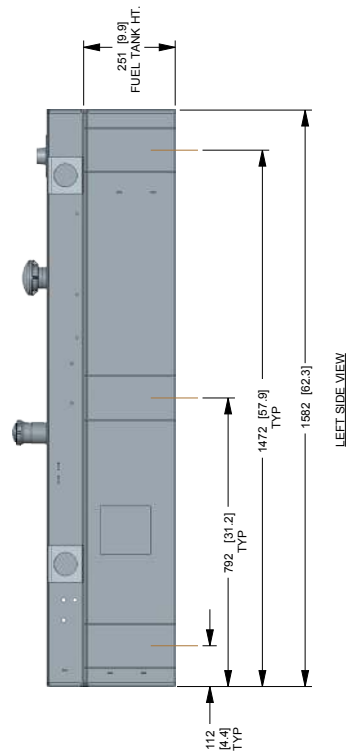
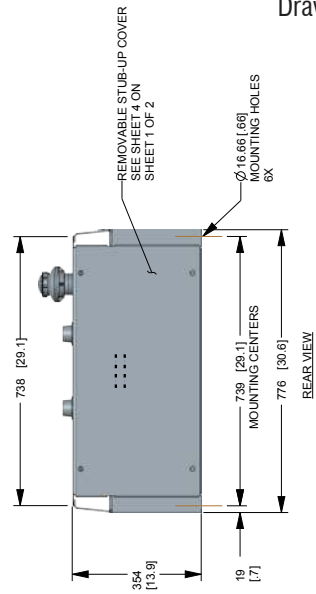
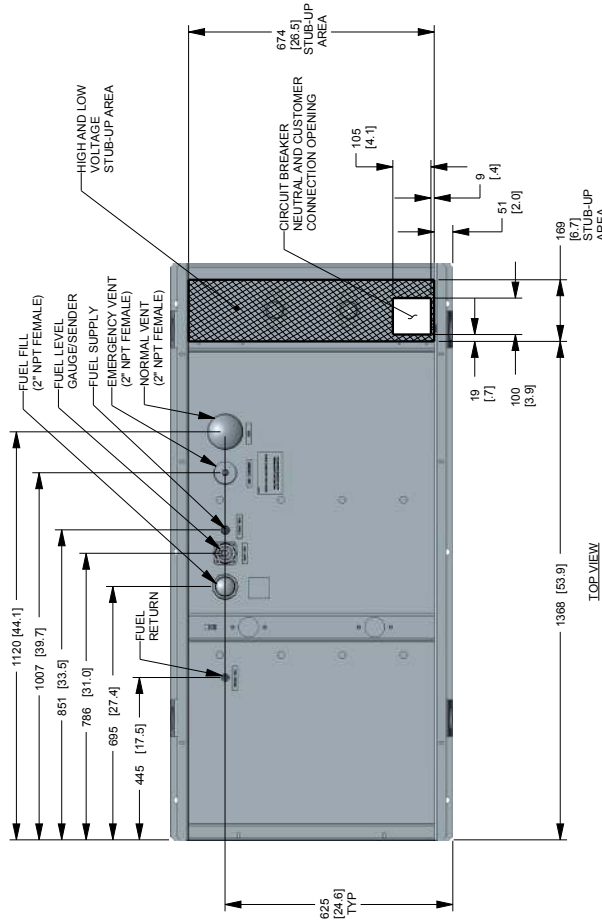

30 kW

Drawing #0K7002A-B (1 of 2)

SERVICE ITEM	WEIGHT DATA WITH EMPTY BASE TANK (SEE NOTE 5)	
	2.4L RIGHT SIDE	GENERATOR AS SHOWN 766 [189.9]
OIL FILL CAP	RIGHT SIDE	
OIL DIP STICK	RIGHT SIDE	
OIL FILTER	RIGHT SIDE	802 [176.9]
OIL DRAIN HOSE	RIGHT SIDE	
RADIATOR DRAIN HOSE	LEFT SIDE	
AIR CLEANER ELEMENT	LEFT SIDE	
MUFFLER	FRONT	
FAN BELT	EITHER SIDE	
BATTERY	LEFT SIDE	

NOTES:

1. MINIMUM RECOMMENDED CONCRETE PAD SIZE: 1.94' (47") WIDE X 2.281' (697") LONG. REFER TO INSTALLATION GUIDE SUPPLIED WITH UNIT FOR CONCRETE PAD GUIDELINES.
2. ALLOW SUFFICIENT ROOM ON ALL SIDES OF THE GENERATOR FOR MAINTENANCE AND SERVICING. THIS UNIT MUST BE INSTALLED IN ACCORDANCE WITH CURRENT APPLICABLE NFPA 37 AND NFPA 70 STANDARDS AS WELL AS ANY OTHER FEDERAL, STATE, AND LOCAL CODES.
3. CONTROL PANEL CIRCUIT BREAKER INFORMATION:
- SEE SPECIFICATION SHEET OR OWNERS MANUAL
- ACCESSIBLE THROUGH CUSTOMER ACCESS ASSEMBLY DOOR ON REAR OF GENERATOR
4. REMOVE THE REAR TANK AND REAR ENCLOSURE COVER PANEL TO ACCESS THE STUD UP AREAS AS FOLLOWS:
- REMOVE THE REAR TANK AND REAR ENCLOSURE COVER PANEL
- NEUTRAL CONNECTION BATTERY CHARGER 120 VOLT AC (0.5 AMP MAX) CONNECTION
- LOW VOLTAGE CONNECTIONS INCLUDING TRANSFER SWITCH CONTROL WIRES
5. CENTER OF GRAVITY AND WEIGHT MAY CHANGE DUE TO UNIT OPTIONS.
6. ENGINE SERVICE CONNECTIONS:
- OIL DRAIN: 3/8" NPT
- FUEL LINE: 1/2" O.D.
7. BOTTOM OF GENERATOR SET MUST BE ENCLOSED TO PREVENT PEST INTRUSION AND RECIRCULATION OF DISCHARGE AIR AND/OR IMPROPER COOLING AIR FLOW.
8. EXHAUST SYSTEM MAXIMUM BACK PRESSURE: 35 INCHES H2O.
9. REFERENCE OWNERS MANUAL FOR LIFTING WARNINGS.
10. MOUNTING BOLTS OR STUDS TO CONCRETE PAD SHALL BE 5/8"-11 GRADE 5 (USE STANDARD SAE TORQUE SPECS)

REFERENCE OWNERS MANUAL FOR PERIODIC REPLACEMENT PART LISTINGS.

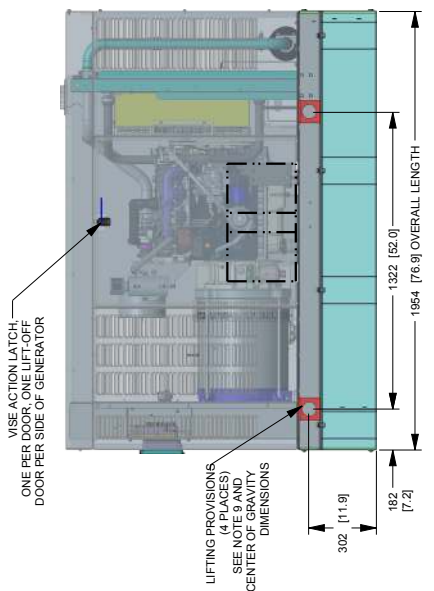
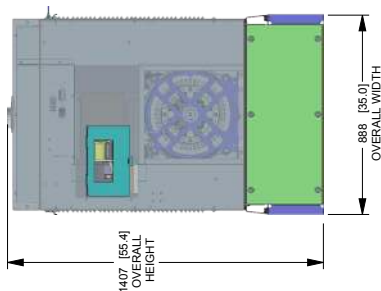
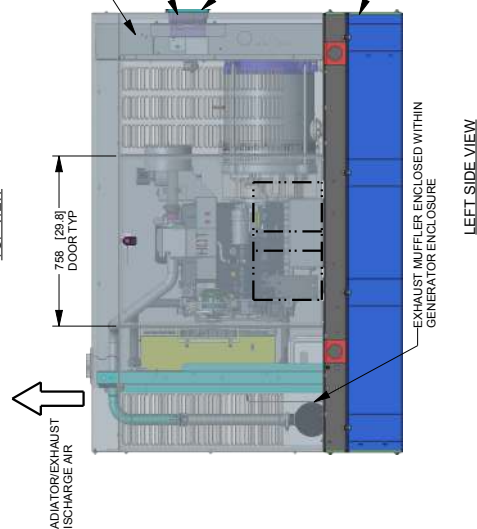
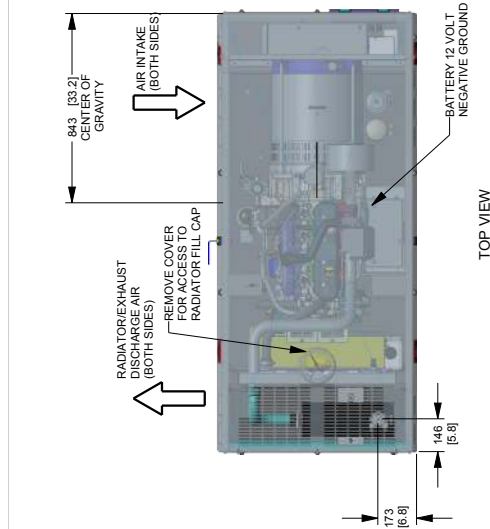

RIGHT SIDE VIEW

REAR VIEW

LEFT SIDE VIEW

30 kW

GENERAC®

installation layout

Drawing #0K7002A-B (2 of 2)

Protector™ Series

9 of 6

FUEL TANK	
TOTAL CAPACITY	253.6 [67]
USABLE CAPACITY	230.9 [61]
CAPACITY: LITER (GALLONS)	
DIMENSIONS: MM (INCH)	

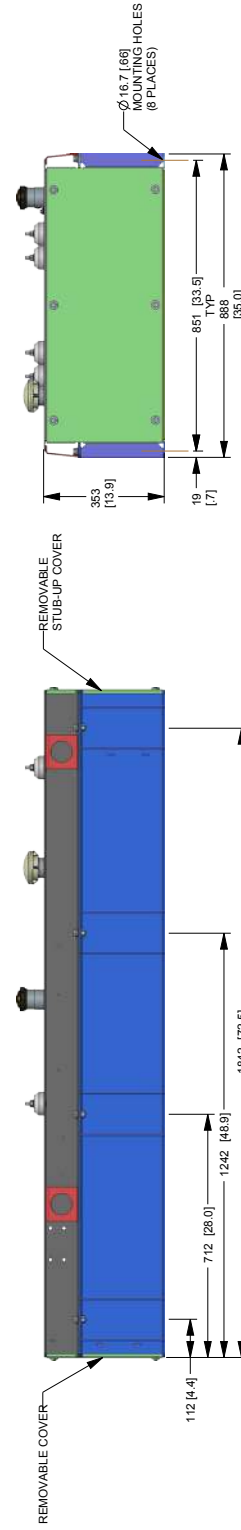
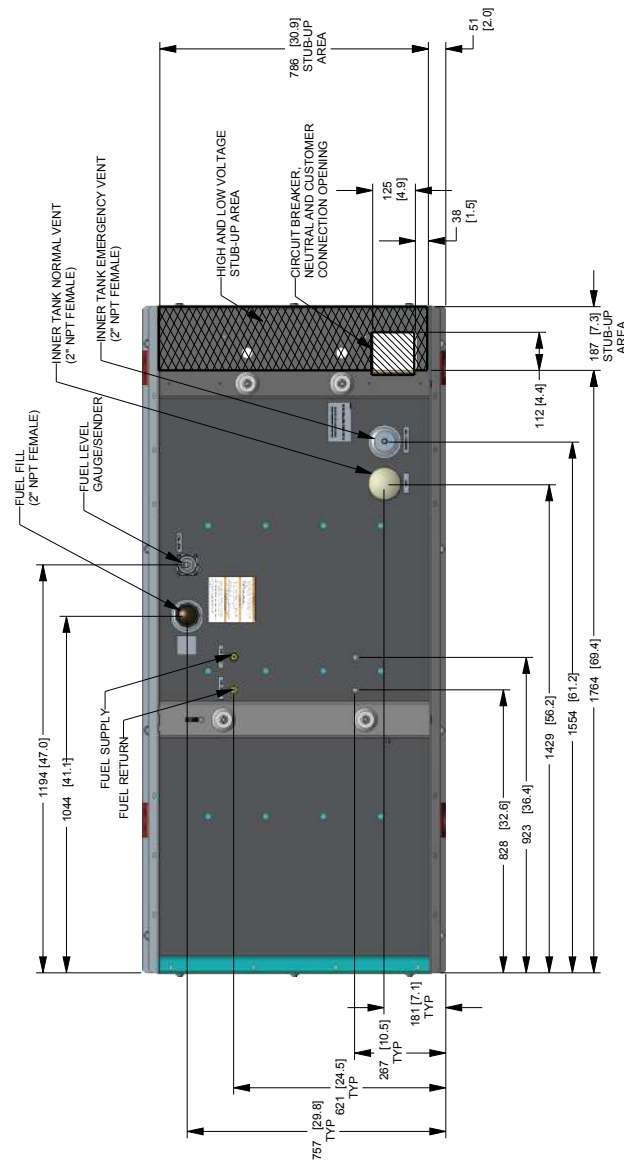

48 & 50 kW

Drawing #0K6968A-A (1 of 2)

SERVICE ITEM	3.4L	WEIGHT DATA WITH EMPTY BASE/TANK (SEE NOTE 5)
OIL FILL CAP	RIGHT SIDE	GENERATOR AS SHOWN (STEEL ENCL.) 888 [1953]
OIL DIP STICK	RIGHT SIDE	WITH WOODEN SHIPPING SKID 925 [2039]
OIL FILTER	RIGHT SIDE	
OIL DRAIN HOSE	RIGHT SIDE	
RADIATOR DRAIN HOSE	LEFT SIDE	
AIR CLEANER ELEMENT	RIGHT SIDE	
MUFFLER	FRONT	
FAN BELT	EITHER SIDE	
BATTERY	LEFT SIDE	

REFERENCE MANUAL FOR PERIODIC REPLACEMENT PART LISTINGS.

NOTES:

1. MINIMUM RECOMMENDED CONCRETE PAD SIZE: 1194 (477") WIDE X 2261 (897") LONG. REFERENCE INSTALLATION GUIDE SUPPLIED WITH UNIT FOR CONCRETE PAD GUIDELINES.
2. ALLOW SUFFICIENT ROOM ON ALL SIDES OF THE GENERATOR FOR MAINTENANCE AND SERVICING. THIS UNIT MUST BE INSTALLED IN ACCORDANCE WITH CURRENT LOCAL, STATE AND FEDERAL CODES, AS WELL AS ANY OTHER FEDERAL, STATE AND LOCAL CODES.
3. CONTROL PANEL / CIRCUIT BREAKER INFORMATION:
 - SEE SPECIFICATION SHEET OR OWNERS MANUAL
 - ACCESSIBLE THROUGH CUSTOMER ACCESS ASSEMBLY COVER PANEL TO REAR OF GENERATOR SET.
 4. REMOVE THE REAR TANK AND REAR ENCLOSURE COVER PANEL TO ACCESS THE SERVICE PANELS AS FOLLOWS:
 - REMOVE THE REAR TANK AND REAR ENCLOSURE COVER PANEL TO ACCESS THE REAR SERVICE PANELS.
 - REMOVE THE REAR TANK AND REAR ENCLOSURE COVER PANEL TO ACCESS THE NEUTRAL CONNECTION, BATTERY CHARGER (20 VOLT AC (0.5 AMP MAX)) CONNECTION, LOW VOLTAGE CONNECTIONS INCLUDE TRANSFER SWITCH CONTROL WIRES.
 5. CENTER OF GRAVITY AND WEIGHT MAY CHANGE DUE TO UNIT OPTIONS.
 6. ENGINE SERVICE CONNECTIONS
 OIL DRAIN: 3/8" NPT
 AIR FILTER: 2" O.D.
 7. BOTTOM OF GENERATOR SET MUST BE ENCLOSED TO PREVENT PEST INTRUSION AND RECIRCULATION OF DISCHARGE AIR AND/OR IMPROPER COOLING AIR FLOW.
 8. EXHAUST SYSTEM MAXIMUM BACK PRESSURE: 35 INCHES H2O.
 9. REFERENCE OWNERS MANUAL FOR LIFTING WARNINGS.
 10. MOUNTING BOLTS OR STUDS TO CONCRETE PAD SHALL BE 5/8-11 GRADE 5

UNITS, WEIGHT - KG (LBS)
 DIMENSION - MM (INCH)

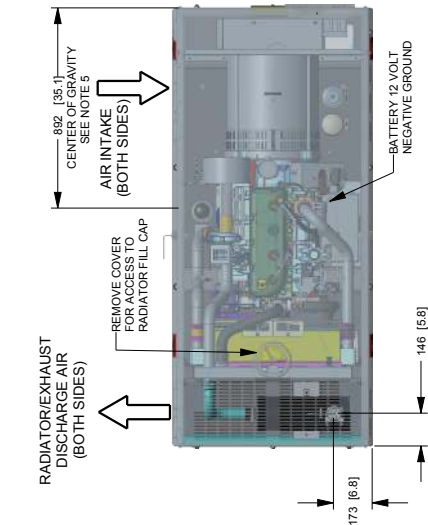

TOP VIEW

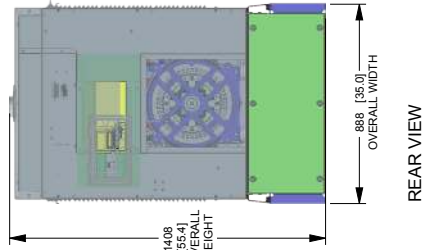

REAR VIEW

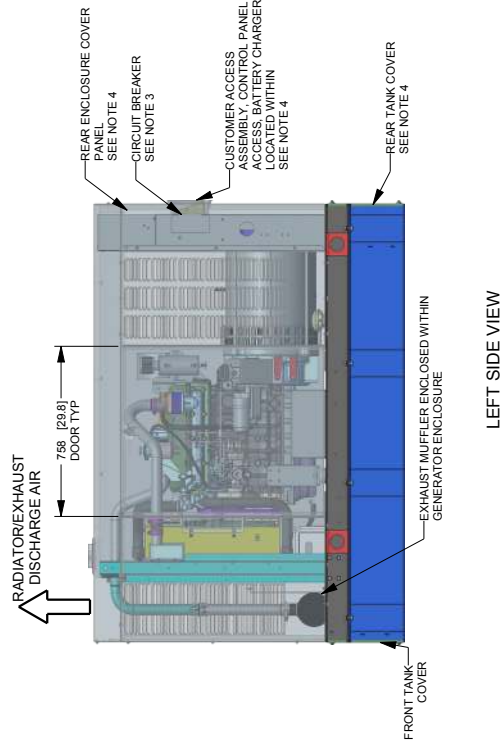

LEFT SIDE VIEW

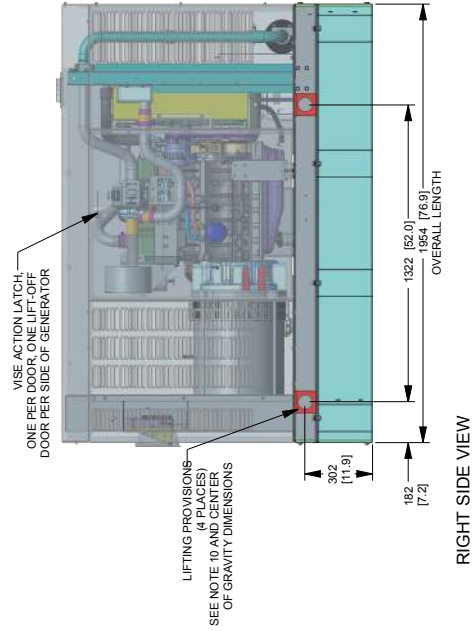

RIGHT SIDE VIEW

48 & 50 kW

FUEL TANK	
TOTAL CAPACITY	253.6 [67]
USABLE CAPACITY	230.9 [61]
CAPACITY, LITER (GALLONS)	
DIMENSIONS: MM [INCH]	

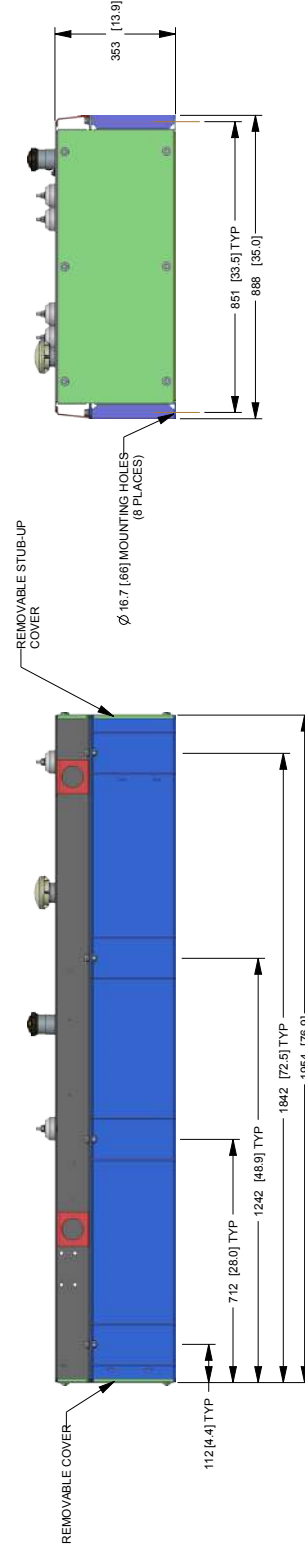
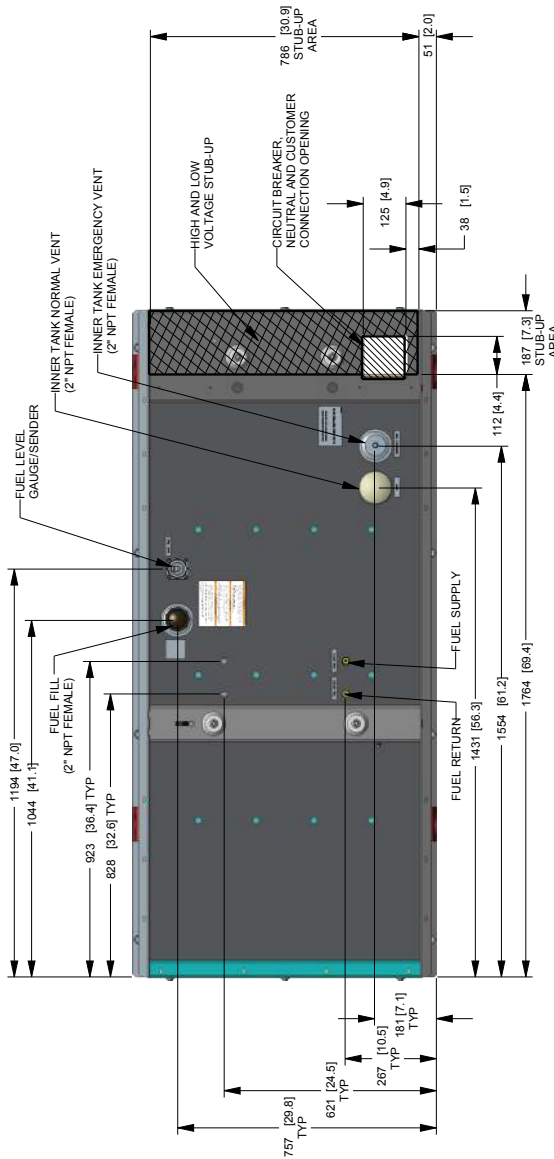

15 • 20 • 30 • 48 • 50 kW

Model #	Product	Description
006505-0 - 15 & 20 kW 006506-0 - 30, 48 & 50 kW	Tank Risers	Tank risers are required in some municipalities to help avoid potential base tank corrosion caused by mounting on rough surfaces.
006512-0	Lockable Fuel Cap	The cast iron, lockable fuel cap provides the ability to lock the fuel system to prevent unwanted fuel tampering or fuel siphoning.
006572-0 - 15 & 20 kW 006571-0 - 30 kW 006570-0 - 48 & 50 kW	Maintenance Kits	The Protector Maintenance Kits offer all the hardware necessary to perform complete maintenance on Ottomotores Protector generators.
006560-0 - 15 & 20 kW 006559-0 - 30 kW 006558-0 - 48 & 50 kW	Cold Weather Kits	Recommended for generators installed in regions where the temperature regularly falls below 32 °F (0 °C). The Cold Weather Kits consist of a block heater with all necessary mounting hardware and a battery warmer with a thermostat built into the battery wrap.
005704-0	Paint Kit	If the generator enclosure is scratched or damaged, it is important to touch-up the paint to protect from future corrosion. The paint kit includes the necessary paint to properly maintain or touch-up a generator enclosure.
006664-0	Local Wireless Remote	Completely wireless and battery powered, Generac's wireless remote monitor provides you with instant status information without ever leaving the house.
006665-0	Wireless Remote Extension Harness	Recommended for use with the Wireless Remote on units up to 60 kW, required for use on units 70 kW or greater.
006873-0	Smart Management Module (50 Amps)	Manage large loads by utilizing up to 8 individual Smart Management modules. These devices are installed directly in line with existing appliance wiring for easy installation.